



## PRODUCT SPECIFICATION

**MODEL:** V1512MM-A MONITOR MOUNT

**PRODUCT CODE:** 6288

**DESCRIPTION:** MEDIUM-DUTY MONITOR MOUNT

- Accommodates VM5093, VM5123 and VM6092 monitors
- Ceiling or wall mounted
- Attractive styling

The V1512MM-A Monitor Mount provides secure, attractive mounting of VM5093, VM5123 and VM6092 monitors. It is finished in black semigloss enamel and black anodized aluminum. It is intended for suspension from either a ceiling or a wall using Model V1512WM Mounting Adapter.

NOTES	SPEC NO.	REV.	SEC.
SUPERSEDES PRODUCT SPECIFICATION 610-189	610	599	7



V1512MM-A MONITOR MOUNT

### ASSOCIATED EQUIPMENT AND ACCESSORIES

**Model V1512WM Mounting Adapter:** Used for suspended mounting of the monitor mount. UL. Product code 2179.

## CONTRACTORS' SPECIFICATION

### MONITOR MOUNT

The monitor mount shall be an adjustable unit, suitable for wall or ceiling mounting of a series of monitors 9 to 12.0 in. (23 to 30.5 cm) wide, and up to 13 in. (33 cm) high. The load rating shall be 30 lb (14 kg). Dimensions shall not exceed: height (H), 16.6 in. (42.2 cm); width (W), 18.8 in. (47.8 cm). Construction shall be of steel and aluminum, and the unit shall weigh 4.8 lb (2.2 kg).

The adjustable monitor mount shall be Vicon model V1512MM-A. Suspended mounting requires Vicon model V1512WM Mounting Adapter.

Product specifications subject to change without notice.  
Copyright © 1999 Vicon Industries Inc. All rights reserved.

Vicon part number 8006-7610-01-00  
Vicon and its logo are registered trademarks of Vicon Industries Inc.

## TECHNICAL INFORMATION

### MECHANICAL

Mounting: 5/16 × 2-inch bolts or lag screws.  
Ceiling or wall (with the use of Model  
V1512WM Mounting Adapter).

Monitor Size: Designed specifically to mount  
VM5093, VM5123 and VM6092  
monitors.  
Width: 9 - 12 in. (23 - 30.5 cm).  
Height: up to 13 in. (33 cm).

Load Rating: 30 lb (14 kg).

Dimensions: Width (W): 18.75 in. (47.62 cm).  
Height (H): 16.62 in. (42.2 cm).

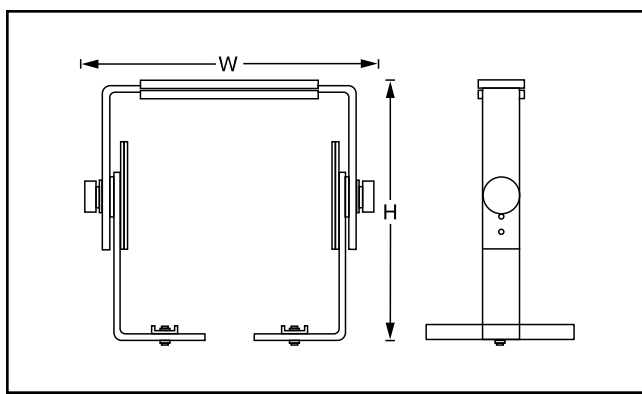

Weight: V1512MM-A: 4.8 lb (2.2 kg).  
V1512WM: 4.0 lb (1.8 kg).

Construction: Aluminum and steel.

Finish: Black semigloss enamel and black  
anodized aluminum.

Shipping Dimensions: V1512MM-A  
Height: 2.5 in. (6.4 cm).  
Width: 13.5 in. (34.3 cm).  
Length: 15.0 in. (38.1 cm).

V1512WM  
Height: 2.5 in. (6.4 cm).  
Width: 8.5 in. (21.6 cm).  
Length: 13.0 in. (33.0 cm).

Shipping Weight: V1512MM-A: 5.8 lb (2.6 kg).  
V1512WM: 4.4 lb (2.0 kg).

Shipping Volume: V1512MM-A: 0.3 ft<sup>3</sup> (0.008 m<sup>3</sup>).  
V1512WM: 0.2 ft<sup>3</sup> (0.004 m<sup>3</sup>).

### ENVIRONMENTAL

Storage  
Temperature Range: -40 to 150° F (-40 to 65° C).

Storage Humidity: Up to 90% relative, noncondensing.



